



Smart Network Building Blocks – From Ethernet to WDM

MS1025: Optical amplifier

MS1025 Optical Amplifier Shelf



Smart Network Building Blocks – From Ethernet to WDM

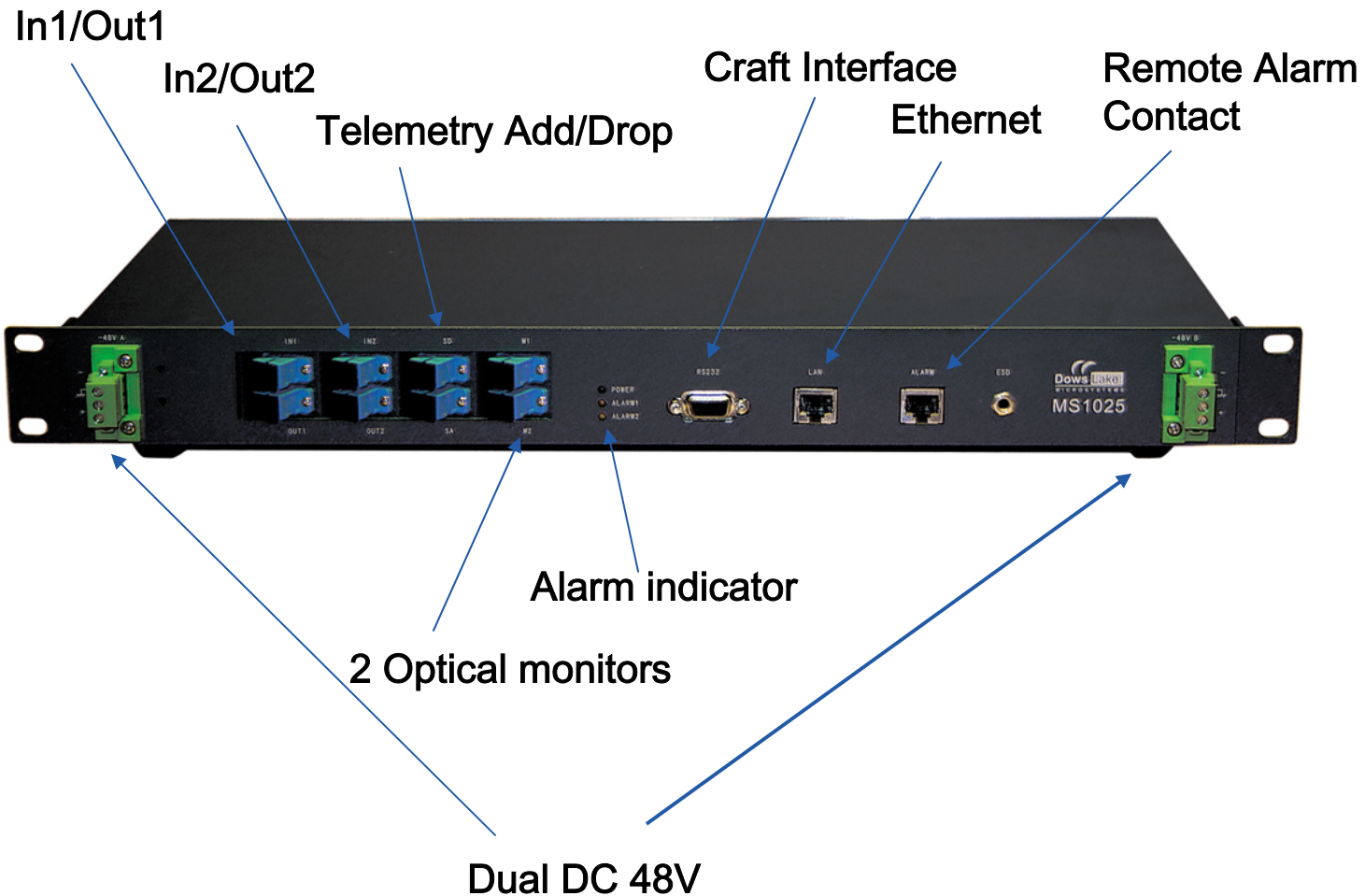

YUMIX MS1025 Applications



Smart Network Building Blocks – From Ethernet to WDM

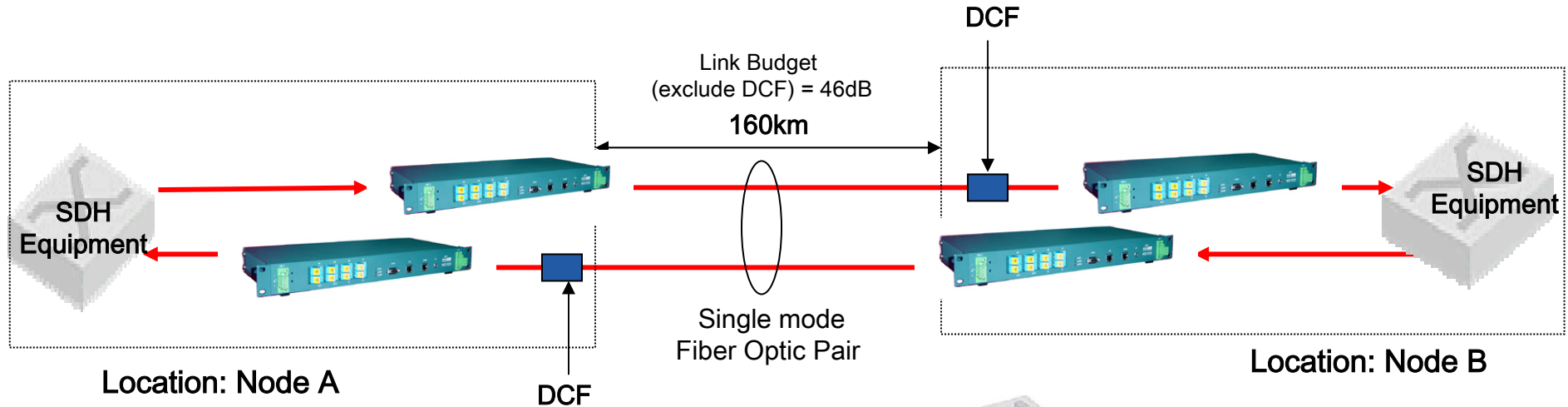

Link Extender

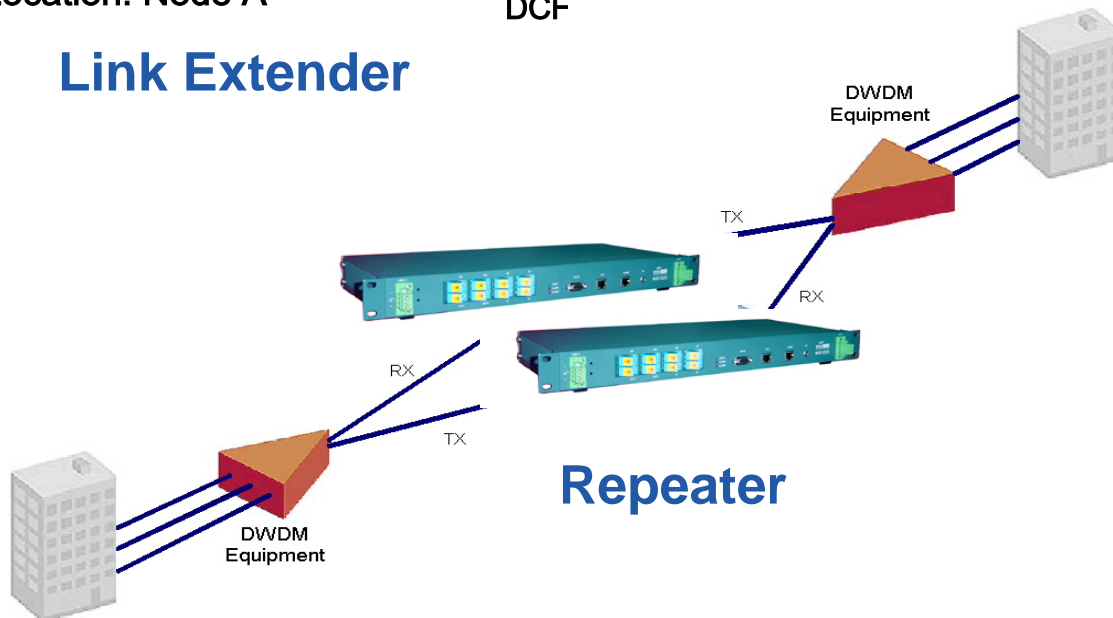

YUMIX MS1025 Features



Smart Network Building Blocks – From Ethernet to WDM

- Single and Simple Platform
- Custom EDFA performance with Client Specific Optical Parameters
- Variable Gain with Integrated VOA Available
- Mid-stage with Automatic DCM Detection Available
- Redundant DC power supply or one AC power supply
- Command Line Interface (CLI), Telnet and TL1
- SNMP and Web-based management